



LP0195

FITTING INSTRUCTIONS FOR LP0195BK LICENCE PLATE BRACKET
MV AGUSTA BRUTALE 1090 2013-

Page | 1



THIS KIT CONTAINS THE ITEMS PICTURED AND LABELLED BELOW.
DO NOT PROCEED UNTIL YOU ARE SURE ALL PARTS ARE PRESENT.

Please note that the way the kit is packed does not necessarily represent the way of mounting to the bike

THE PARTS SHOWN MAY BE REPRESENTATIVE ONLY (FOR CLARITY OF INSTRUCTIONS ONLY)

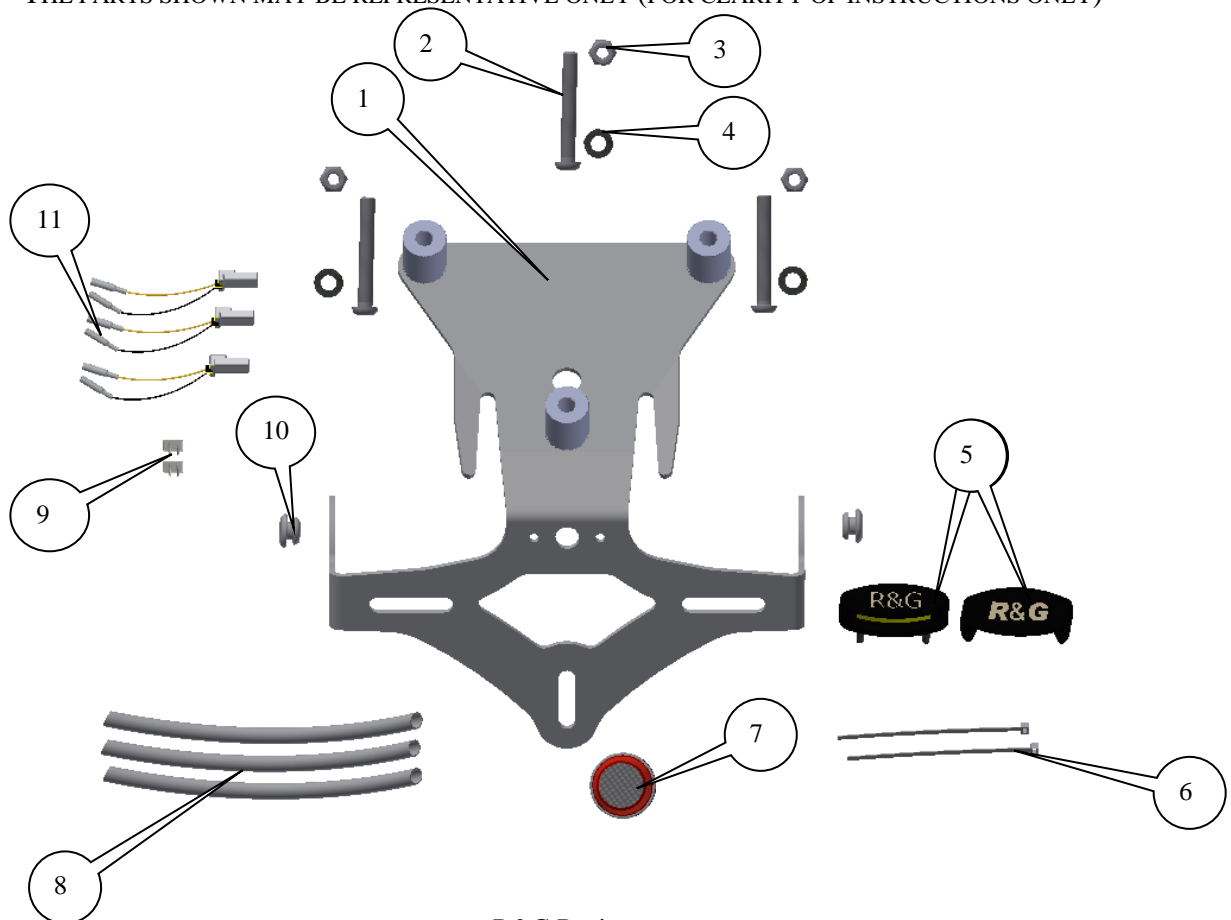

R&G Racing

Unit 1, Shelley's Lane, East Worldham, Alton, Hampshire, GU34 3AQ

Tel: +44 (0)1420 89007 Fax: +44 (0)1420 87301 www.rg-racing.com Email: info@rg-racing.com



LP0195

LEGEND

- ITEM 1 = LICENCE PLATE BRACKET (TB0195) (x1) (with (3x S0506 SWAGED IN POSITION).
- ITEM 2 = M6 x 45mm LONG BUTTON HEAD BOLT (x3).
- ITEM 3 = M6 NYLOC NUT (x3).
- ITEM 4 = M6 WASHER (x3).
- ITEM 5 = LA0002 No PLATE LIGHT ASSEMBLY (x1).
- ITEM 6 = CABLE TIES (x2).
- ITEM 7 = REFLECTOR (REFL 1) (x1).
- ITEM 8 = 150mm LENGTH OF HEAT SHRINK (x3).
- ITEM 9 = CABLE CLIPS (x2).
- ITEM 10 = RB80-30-00 RUBBER GROMMETS (x2)
- ITEM 11 = LICENCE PLATE ILLUMINATOR AND INDICATOR CONNECTORS (CON0014) (x3).

Page | 2

Please note that in cases where kits are packed with rubber washers holding the components onto the bolt – *the rubber washers should be thrown away!*

TOOLS REQUIRED

- Set of Metric Allen keys to include 4mm A/F.
 - 8 and 10mm Socket and wrench.
 - 8 and 10mm Spanners.
 - Small amount of super glue.



PICTURE 1

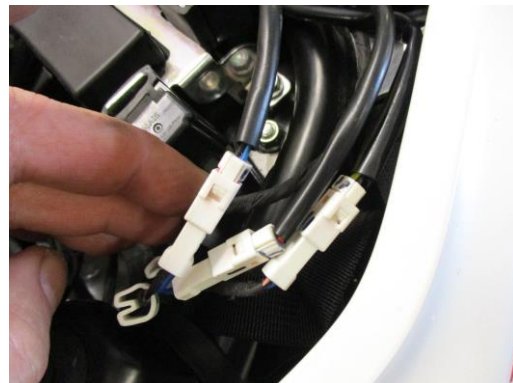

PICTURE 2

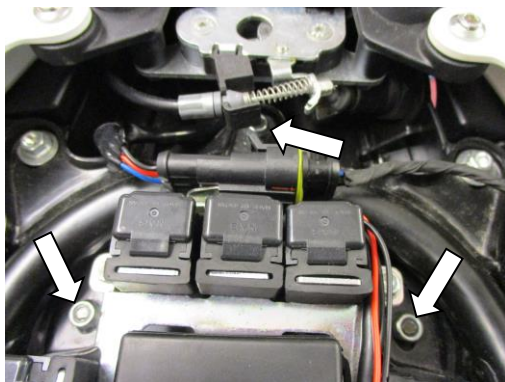

PICTURE 3



PICTURE 4



LP0195

Page | 3

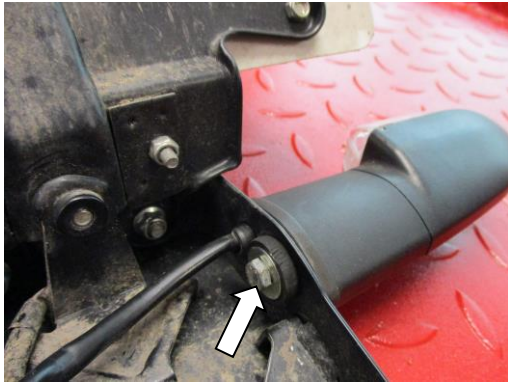

PICTURE 5



PICTURE 6



PICTURE 7



PICTURE 8



PICTURE 9



PICTURE 10



LP0195

Page | 4

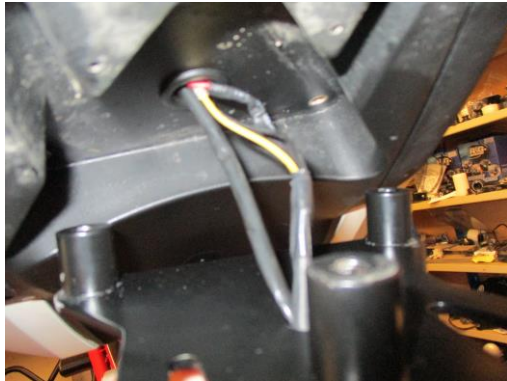

PICTURE 11



PICTURE 12

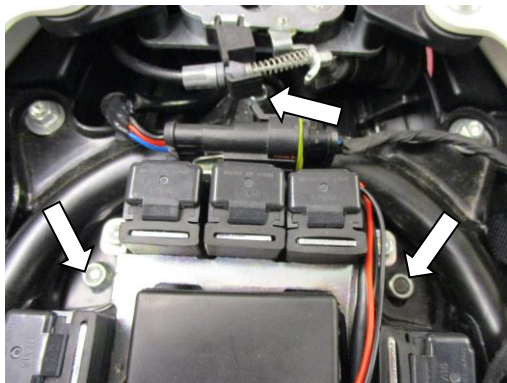

PICTURE 13



PICTURE 14

FITTING INSTRUCTIONS

- Remove the seat unit using the key, as shown in picture 1.
- Disconnect the licence plate and indicator electrical connections, as shown in picture 2. *It's a good idea to mark the matching connectors up at this stage to make re-fitting easier.*
- Remove the three nuts that secure the licence plate assembly in place, as arrowed in picture 3.
- The license plate assembly will now be free. Feed the cables through the hole on the underside of the tail, as shown in picture 4. The assembly can now be taken away from the bike.
- If you intend to use the OEM indicators, then remove the indicator mounting bolt and feeding the cable out through the hole, as shown in pictures 5 and 6, repeat for opposite side), then fit to the new licence plate bracket (item 1) as shown in pictures 7 and 8.
- If using mini's fit the indicators of choice to the new licence plate bracket (item 1) (R&G mini indicator product code RG370 for bulb type and RG371 for LED type or RG372 for Aero Style led type) as shown in picture 9 (please use the provided heat shrink (item 8) to protect the wiring). *If fitting the R&G Mini Indicators, use the two rubber grommets (item 10) to plug the unused hole.*
- Take the R&G Licence Plate Bracket (item 1 – TB0195) and fit the licence plate illuminator (item 5), as shown in picture 10. Use a small amount of superglue to stick the

R&G Racing

Unit 1, Shelley's Lane, East Worldham, Alton, Hampshire, GU34 3AQ

Tel: +44 (0)1420 89007 Fax: +44 (0)1420 87301 www.rg-racing.com Email: info@rg-racing.com



LP0195

Page | 5

light shroud in position. (Please use the heat shrink (item 8) to protect the new licence plate illuminator wires).

- Cable-tie the wires neatly together on the underside of the tail tidy. The self-adhesive cable clips can also be used, positioned either side, as shown in picture 8.
- Place the tail tidy assembly on the rear wheel whilst the wiring is placed through the hole on the underside of the tail, as shown in picture 11.
- Offer the tail tidy assembly up to the underside of the tail unit (as shown in picture 12) and place one of the three M6 x 45mm Button Head Bolts (item 2) through the licence plate bracket from the underside, and into the location point within the rear sub-frame, as shown in picture 13. With the exposed thread of the bolt protruding from above, place a washer and M6 Nyloc Nut (items 3 and 4) onto the bolt and loosely tighten.
- Fit the two remaining bolts through the licence plate bracket in the same way, and loosely tighten the Nyloc nuts.
- With all three bolts in place, these can be tightened. *Please ensure the wires are not trapped.*
- Connect the licence plate illuminator using one of the supplied connectors (item 11) (if the licence plate illuminator fails to light please swap the bullet connectors over), if using original indicators, connect to the main loom on the bike as original (as they were marked up earlier) and check the operation of the indicators and lights. If using R&G mini indicators please use the two remaining connectors (item 11) to connect to the main loom. If using R&G LED type indicators, resistors (R&G product code RGR0001) will have to be used to achieve the correct flash rate (if illumination fails please swap the bullet connectors over).
- **IMPORTANT: IF FITTING A FULL-SIZE LICENCE PLATE AND PLACING IT FAR DOWN ON THE LICENCE PLATE HANGER, THERE IS A SMALL CHANCE OF THE LICENCE PLATE HITTING THE BACK WHEEL UNDER HEAVY LOAD AND OVER LARGE BUMPS IN THE ROAD. IT IS YOUR RESPONSIBILITY TO CHECK FOR THIS POSSIBILITY AND TAKE AVOIDING ACTION. FAILURE TO CHECK THIS COULD RESULT IN SERIOUS INJURY.**
- Refit the seat unit and licence plate (it may require drilling).
- Depending on local laws, attach enclosed reflector (item 7) in an appropriate location.
- **Please test the indicators, rear light and licence plate illuminator before riding.**

Digital copies of these instructions are available to download from www.rg-racing.com

GENERAL TORQUE SETTINGS

M4 BOLT = 8Nm
M5 BOLT = 12Nm
M6 BOLT = 15Nm
M8 BOLT = 20Nm
M10 BOLT = 40Nm

ISSUE 1 20/04/2016 (NSY)

CONSUMER NOTICE

The catalogue description and any exhibition of samples are only broad indications of the Products and R&G may make design changes which do not diminish their performance or visual appeal and supplying them in such state shall conform to the order. The Buyer acknowledges no representation or warranty (other than as to title) has been given or will apply to the Products other than those in R&G's order or confirmation and the Buyer confirms it has chosen the Products as being of merchantable quality and suitable for its particular purposes. Where R&G fits the Products or undertakes other services it shall exercise reasonable skill and care and rectify any fault free of charge unless the workmanship has been disturbed. The Buyer is responsible for ensuring that the warranty on the motorcycle is not affected by the fitting of the Products. On return of any defective Products R&G shall at its option either supply a replacement or refund the purchase money but shall not be liable if the Products have been modified or used or maintained otherwise than in accordance with R&G's or manufacturer's instructions and good engineering practice or if the defect arises from accident or neglect. Other than identified above and subject to R&G not limiting

R&G Racing

Unit 1, Shelley's Lane, East Worldham, Alton, Hampshire, GU34 3AQ

Tel: +44 (0)1420 89007 Fax: +44 (0)1420 87301 www.rg-racing.com Email: info@rg-racing.com



LP0195

its liability for causing death and personal injury, it shall not be liable for indirect or consequential loss and otherwise its liability shall be limited to the amounts paid by the Buyer for the Products or the fitting or service concerned. These terms do not affect the Buyer's statutory rights.

R&G RACING RETURNS POLICY (NON-FAULTY GOODS)

Returns must be pre-authorized (if not pre-authorized the return will be rejected). Goods may only be returned direct to us if they were purchased direct from us (customer must prove if necessary). Otherwise to be returned to original vendor. Goods must be in re-sellable condition, in the opinion of R&G Racing. All returns are subject to a 25% restocking and handling fee (25% of the gross value exc. P&P – at the prevailing price at time of purchase). The customer must pay any and all carriage charges. No returns of discontinued products, unless within 14 days of purchase. This policy does not affect your statutory rights and does not refer to faulty goods.



LP0195

NOTICE DE MONTAGE POUR LP0195BK SUPPORT DE PLAQUE
MV AGUSTA BRUTALE 1090 2015-

Page | 7



Le kit contient les articles exposés ci-dessous, vérifier que toutes les pièces soient présentes avant de procéder au montage.

LA FAÇON DONT LE KIT EST EMBALLE NE CORRESPOND PAS FORCEMENT A LA FAÇON DE MONTER LES PIÈCES SUR LA MOTO.

LES PARTIES PRESENTÉES PEUVENT ÊTRE UNIQUEMENT REPRESENTATIVES (POUR LA CLARTE DES INSTRUCTIONS UNIQUEMENT)

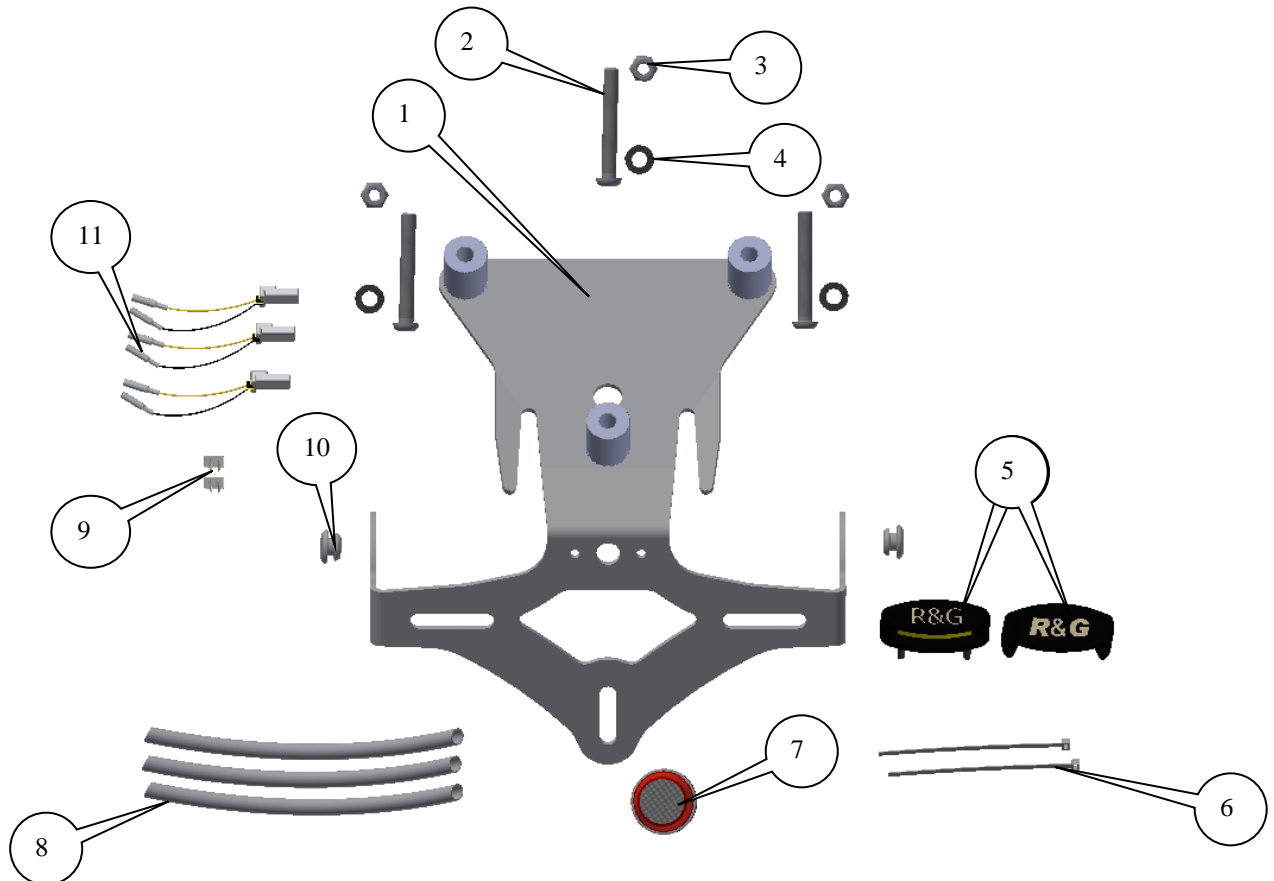

Unit 1, Shelley's Lane, East Worldham, Alton, Hampshire, GU34 3AQ
Tel: +44 (0)1420 89007 Fax: +44 (0)1420 87301 www.rg-racing.com Email: info@rg-racing.com



LP0195

LEGENDE

ARTICLE 1 = SUPPORT DE PLAQUE (TB0195) (x1) (avec (3x S0506 sertis en position).

ARTICLE 2 = BOULON M6 x 45mm (x3).

ARTICLE 3 = ECROU M6 (x3).

ARTICLE 4 = RONDELLE M6 (x3).

ARTICLE 5 = ASSEMBLAGE FEU DE PLAQUE LA0002 No (x1).

ARTICLE 6 = COLLIERS DE SERRAGE (x2).

ARTICLE 7 = REFLECTEUR (REFL 1) (x1).

ARTICLE 8 = LONGUEUR DE MOUSSE AUTOCOLLANTE 150mm (x3).

ARTICLE 9 = CLIPS CABLE (x2).

ARTICLE 10 = RONDELLES DE CATOUCHOU RB80-30-00 (x2)

ARTICLE 11 = FEU DE PLAQUE ET CONNECTEURS CLIGNOTANT (CON0014)

(x3).

Page | 8

Notez que si les kits sont emballés avec des rondelles en caoutchouc servant à tenir les composants, *ces rondelles doivent être jetées !*

OUTILS REQUIS

- Jeu de clés Allen 4mm.
- Clé à douille 8 and 10mm
- Clé à molette 8 et 10mm.
- Un peu de superglue.

NOTICE DE MONTAGE

- Enlever le siège à l'aide d'une clé, voir photo 1.
- Déconnecter la plaque et les connections de clignotant, voir photo 2. *Il est bon de noter les correspondances de connecteurs pour rendre le remontage plus facile.*
- Enlever les 3 écrous qui fixent l'assemblage de plaque en place, voir photo 3.
- L'assemblage de plaque sera maintenant libéré. Passer les câbles dans le trou au bas de la queue de support de plaque, voir photo 4. L'assemblage peut à présent être extrait de la moto.
- Si vous souhaitez utiliser les clignotants d'origine, enlever le boulon de fixation de clignotant puis passer le câble dans le trou, voir photos 5 et 6, répéter du côté opposé, puis monter le nouveau support de plaque (article 1) voir photos 7 et 8.
- Si vous montez les mini clignotants de votre choix sur le nouveau support de plaque (article 1) (mini clignotant R&G code RG370 pour type ampoule et RG371 pour type LED ou RG372 pour type LED latéral) voir photo 9 (Utiliser la thermo rétractable fournie (article 8) pour protéger les fils). *Si vous montez les mini clignotants R&G, utiliser les 2 oeillets de caoutchouc (article 10) pour boucher le trou non utilisé.*
- Prendre le support de plaque R&G (article 1 – TB0195) et monter le feu de plaque (article 5), voir photo 10. Utiliser un peu de superglue pour coller le lincol de feu en position. (Utiliser de la thermo rétractable (article 8) pour protéger les fils de feux de plaque).
- Serrer les fils avec les colliers de serrage ensemble au dessous du passage de roue. Les clips câble autocollant peuvent aussi être utilisés, de chaque côté, voir photo 8.
- Placer l'assemblage de support de plaque sur la roue arrière tout en plaçant le fil dans le trou au dessous de la queue du support de plaque, voir photo 11.
- Monter l'assemblage de support de plaque au dessous de l'unité de support de plaque (voir photo 12) et placer un des 3 boulons M6 x 45mm (article 2) dans le support de plaque au dessous, et dans le point d'emplacement dans le sous-cadre arrière, voir photo

R&G Racing

Unit 1, Shelley's Lane, East Worldham, Alton, Hampshire, GU34 3AQ

Tel: +44 (0)1420 89007 Fax: +44 (0)1420 87301 www.rg-racing.com Email: info@rg-racing.com



LP0195

13. Une fois le filetage du boulon dépassant au dessus, placer une rondelle et un écrou M6 (articles 3 et 4) sur le boulon et serrer légèrement.

- Insérer les 2 boulons restants dans le support de plaque de la même façon, puis serrer légèrement les écrous.
- Une fois les 3 boulons en place, ils peuvent être serrés. *Veiller à ce que les fils ne puissent pas être pincés.*
- Connecter le feu de plaque à l'aide des connecteurs fournis (article 11) (Si le feu de plaque ne s'allume pas, tournez les connecteurs), Si vous utilisez les connecteurs d'origine, connecter le linceul principal sur la moto comme à l'origine (comme ils ont été marqués précédemment) et vérifier le fonctionnement des clignotants et feux. Si vous utilisez les mini clignotants R&G, utiliser les 2 mini clignotants restants (article 11) pour connecter le linceul principal. Si vous utilisez les clignotants R&G type LED, vous devrez utiliser les résistances (code produit RGR0001) pour obtenir le bon éclairage (Si l'éclairage échoue, tournez les connecteurs).
- **IMPORTANT: Si vous installez une grosse plaque, il y a un risque que la plaque entre en contact avec la roue arrière en cas de choc sur la route (bosse, grosse charge etc...). Il est de votre responsabilité de vérifier que cela ne puisse pas se produire. Ne pas effectuer ces vérifications peut entraîner des dommages ainsi que des blessures graves pour le pilote.**
- Remettre le siège et la plaque (peut nécessiter un perçage).
- Selon la loi locale, attachez le réflecteur (article 13) fourni à son emplacement approprié
- **Vérifiez que les clignotants et les feux de plaque fonctionnent bien avant de prendre la route.**

Page | 9

Notice disponible sur www.rg-racing.com

COUPLES DE SERRAGE RECOMMANDÉS :

M4 BOULON = 8Nm
M5 BOULON = 12Nm
M6 BOULON = 15Nm
M8 BOULON = 20Nm
M10 BOULON = 40Nm

ISSUE 1 20/04/2016 (NSY)

CONSUMER NOTICE

The catalogue description and any exhibition of samples are only broad indications of the Products and R&G may make design changes which do not diminish their performance or visual appeal and supplying them in such state shall conform to the order. The Buyer acknowledges no representation or warranty (other than as to title) has been given or will apply to the Products other than those in R&G's order or confirmation and the Buyer confirms it has chosen the Products as being of merchantable quality and suitable for its particular purposes. Where R&G fits the Products or undertakes other services it shall exercise reasonable skill and care and rectify any fault free of charge unless the workmanship has been disturbed. The Buyer is responsible for ensuring that the warranty on the motorcycle is not affected by the fitting of the Products. On return of any defective Products R&G shall at its option either supply a replacement or refund the purchase money but shall not be liable if the Products have been modified or used or maintained otherwise than in accordance with R&G's or manufacturer's instructions and good engineering practice or if the defect arises from accident or neglect. Other than identified above and subject to R&G not limiting its liability for causing death and personal injury, it shall not be liable for indirect or consequential loss and otherwise its liability shall be limited to the amounts paid by the Buyer for the Products or the fitting or service concerned. These terms do not affect the Buyer's statutory rights.

R&G RACING RETURNS POLICY (NON-FAULTY GOODS)

Returns must be pre-authorized (if not pre-authorized the return will be rejected). Goods may only be returned direct to us if they were purchased direct from us (customer must prove if necessary). Otherwise to be returned to original vendor. Goods must be in re-sellable condition, in the opinion of R&G Racing. All returns are subject to a 25% restocking and handling fee (25% of the

R&G Racing

Unit 1, Shelley's Lane, East Worldham, Alton, Hampshire, GU34 3AQ

Tel: +44 (0)1420 89007 Fax: +44 (0)1420 87301 www.rg-racing.com Email: info@rg-racing.com



LP0195

gross value exc. P&P – at the prevailing price at time of purchase). The customer must pay any and all carriage charges. No returns of discontinued products, unless within 14 days of purchase. This policy does not affect your statutory rights and does not refer to faulty goods.